

ATTENTION  
BEFORE BEGINNING THE INSTALLATION OF YOUR NEW GRILL,  
ENSURE THAT THE KIT YOU HAVE RECEIVED MATCHES YOUR  
TRUCK MODEL

**PLEASE READ THE INSTRUCTIONS  
COMPLETELY BEFORE BEGINNING**

INSTALLATION INSTRUCTIONS

- 1- ARRANGE THE LOUVER BARS AND SURROUND PIECES ON A FLAT SURFACE. THE PART NUMBERS FOR THE SURROUND ARE ETCHED ON THE PARTS AND SHOULD BE ARRANGED AS FOLLOWS: CL7323022-U03 IS DRIVER AND PASSENGER SIDE, CL7323022-U02 IS THE BOTTOM, CL7323022-U04 IS THE TOP AND CL7323022-U01 IS THE LOUVERS STYLE BARS.
- 2- REMOVE THE COMPLETE FACTORY GRILL FROM THE HOOD AND REMOVE THE FRIEHTLINER LOGO. RETAIN ALL MOUNTING HARDWARE.
- 3- REMOVE THE FACTORY GRILL BAR ASSEMBLY AND BLACK SCREEN FROM THE FACTORY GRILL FRAME.
- 4- REMOVE THE BLACK WIRE SCREEN FROM THE FACTORY GRILL BAR ASSEMBLY AND SET ASIDE FOR A FURTHER STEP. DISCARD THE FACTORY GRILL BAR ASSEMBLY THIS PART WILL NOT BE NEEDED WITH THE NEW GRILL.
- 5- PLACE GRILL SURROUNDS OVER FACTORY FRAME (FRAME SHOULD BE ON A FLAT SURFACE). USE THE LOUVERS STYLE BARS TO PLACE THE GRILL SURROUND PIECES AT THE RIGHT POSITION. MARK THE FACTORY FRAME THROUGH THE SQUARE HOLES ON EACH SURROUND PIECES. REMOVE THE GRILL SURROUND PIECES. DRILL THE MARKED LOCATIONS ON THE FACTORY FRAME TO 5/16" HOLES.

**NOTE 1**  
THE BLACK WIRE SCREEN IS  
PLACE BETWEEN THOSE TWO PART IN STEP #9.

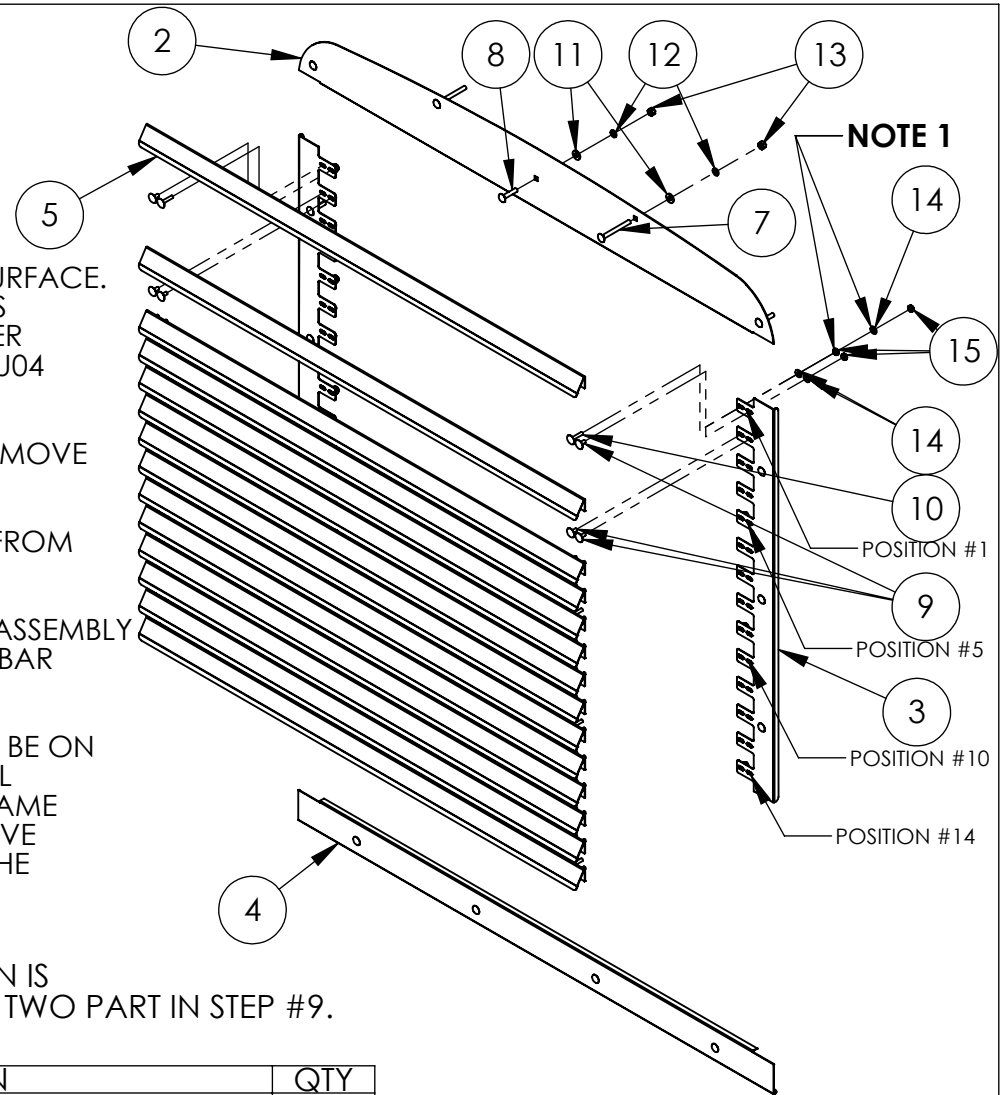

ITEM NO.	PART NUMBER	DESCRIPTION	QTY
1	M7323022CC	FRONT GRILL	1
2	-	PR7323022-U04	1
3	-	PR7323022-U03	2
4	-	PR7323022-U02	1
5	-	PR7323022-U01	14
6	K7223022BB	BOLTS KIT INCLUDES :	1
7	-	CARRIAGE BOLT 1/4-20 X 2 1/2" LG	2
8	-	CARRIAGE BOLT 1/4-20 X 1 1/4" LG	13
9	-	CARRIAGE BOLT 10-32NFX1/2" SS	48
10	-	CARRIAGE BOLT 10-32NFX1" SS	8
11	-	FLAT WASHER 1/4" SS	15
12	-	LOCK WASHER 1/4" SS	15
13	-	HEX NUT 1/4-20NC	15
14	-	FLAT WASHER ID#10 X OD 1/2" SS	64
15	-	NYLON LOCK NUT #10-32NF SS	64

**TRUX ACCESSORIES**

TITLE:  
FRONT GRILL  
FREIGHTLINER CLASSIC FLD 06&UP

SIZE DWG. NO.  
**A TF-1003**

NAME	DATE	REV	DATE
DRAWN BY P.W.	02-12-2008	PH1	-

SCALE: 1:12      WEIGHT: LBS      SHEET: 1 OF 1

## INSTALLATION INSTRUCTIONS

- 6- PEEL THE PVC FILM FROM THE FOUR GRILL SURROUND PIECES AND INSTALL THEM ONTO THE FACTORY FRAME USING 1 ¼"LG CARRIAGE BOLTS, FLAT WASHERS, LOCK WASHERS AND HEX NUTS. USE THE 2 ½"LG CARRIAGE BOLTS IN THE TOP 2 HOLES IN THE UPPER STAINLESS SURROUND. IF YOU WISH TO REINSTALL THE FACTORY LOGO, DRILL FROM BEHIND THE FACTORY FRAME THROUGH THE UPPER STAINLESS SURROUND AND REPLACE LOGO.
  
- 7- TAKE THE -U01 PARTS AND PEEL THE PVC FILM AWAY FROM THE BOLT HOLES OF EACH LOUVERS STYLE BARS. INSTALL FOUR LOUVERS STYLE BARS AS FOLLOW: 1ST IN POSITION #1, 2ND IN POSITION #5, 3RD IN POSITION #10 AND THE 4TH ONE IN POSITION #14 USING 3/16" Ø CARRIAGE BOLTS, FLAT WASHERS AND LOCKNUTS. THE OUTERMOST HOLES ON THE TABS USE ½"LG CARRIAGE BOLTS AND THE INNERMOST HOLES USE 1"LG CARRIAGE BOLTS, FULLY TIGHTEN THESE BOLTS.
  
- 8- INSTALL THE REMAINING LOUVERS STYLE BARS USING 3/16" Ø X ½"LG GARRIAGE BOLTS, FLAT WASHERS AND LOCKNUTS. FULLY TIGHTEN THESE BOLTS.
  
- 9- PLACE THE BLACK WIRE SCREEN OVER THE EIGHT 1"LG CARRIAGE BOLTS THAT WERE INSTALLED IN STEP #7 AND SECURE THEM WITH FLAT WASHERS AND LOCKNUTS.
  
- 10- HOLD THE FULLY ASSEMBLED HORIZONTAL GRILL IN POSITION ON THE FRONT OF THE HOOD. MARK THE LOCATIONS WHERE THE TOP 2 ½"LG CARRIAGE BOLTS FROM STEP #6 CONTACT THE FRONT OF THE HOOD. DRILL THE MARKED LOCATIONS TO 5/16" Ø HOLES.
  
- 11- OPEN THE HOOD. INSTALL THE ASSEMBLED HORIZONTAL GRILL ON THE FRONT OF THE HOOD USING THE HARDWARE REMOVED IN STEP#2. IT MAY BE HELPFUL TO HAVE ANOTHER PERSON TO HOLD THE GRILL.
  
- 12- USE ¼" Ø FLAT WASHERS, LOCK WASHERS AND HEX NUTS ON THE 2 ½"LG FROM STEP #6 AND #10, DO NOT OVERTIGHTEN.
  
- 13- TIGHTEN ALL BOLTS AND PEEL THE REMAINING PVC FILM FROM YOUR GRILL.

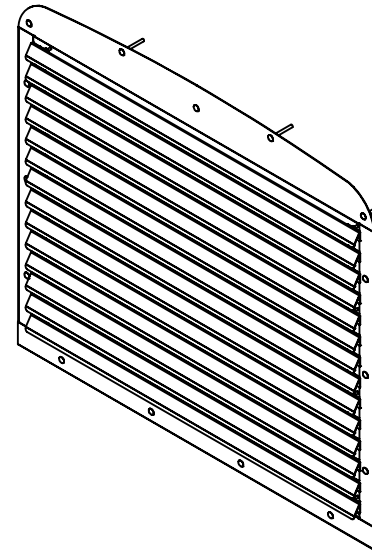

<b>TRUX ACCESSORIES</b>			
TITLE: FRONT GRILL FREIGHTLINER CLASSIC FLD 06&UP			
SIZE	DWG. NO.		
<b>A</b>	<b>TF-1003</b>		
NAME	DATE	REV	DATE
DRAWN BY P.W.	02-12-2008	PH1	-
SCALE: 1:12		WEIGHT: LBS	SHEET: 1 OF 1